

# 74HC595; 74HCT595

8-bit serial-in, serial or parallel-out shift register with output latches; 3-state

Rev. 8 — 25 February 2016

Product data sheet

## 1. General description

---

The 74HC595; 74HCT595 is an 8-bit serial-in/serial or parallel-out shift register with a storage register and 3-state outputs. Both the shift and storage register have separate clocks. The device features a serial input ( $\overline{DS}$ ) and a serial output ( $Q7S$ ) to enable cascading and an asynchronous reset  $\overline{MR}$  input. A LOW on  $\overline{MR}$  will reset the shift register. Data is shifted on the LOW-to-HIGH transitions of the  $\overline{SHCP}$  input. The data in the shift register is transferred to the storage register on a LOW-to-HIGH transition of the  $\overline{STCP}$  input. If both clocks are connected together, the shift register will always be one clock pulse ahead of the storage register. Data in the storage register appears at the output whenever the output enable input ( $\overline{OE}$ ) is LOW. A HIGH on  $\overline{OE}$  causes the outputs to assume a high-impedance OFF-state. Operation of the  $\overline{OE}$  input does not affect the state of the registers. Inputs include clamp diodes. This enables the use of current limiting resistors to interface inputs to voltages in excess of  $V_{CC}$ .

## 2. Features and benefits

---

- 8-bit serial input
- 8-bit serial or parallel output
- Storage register with 3-state outputs
- Shift register with direct clear
- 100 MHz (typical) shift out frequency
- Complies with JEDEC standard no. 7A
- Input levels:
  - ◆ For 74HC595: CMOS level
  - ◆ For 74HCT595: TTL level
- ESD protection:
  - ◆ HBM JESD22-A114F exceeds 2000 V
  - ◆ MM JESD22-A115-A exceeds 200 V
- Multiple package options
- Specified from  $-40\text{ }^{\circ}\text{C}$  to  $+85\text{ }^{\circ}\text{C}$  and from  $-40\text{ }^{\circ}\text{C}$  to  $+125\text{ }^{\circ}\text{C}$

## 3. Applications

---

- Serial-to-parallel data conversion
- Remote control holding register

## 4. Ordering information

Table 1. Ordering information

Type number	Package			
	Temperature range	Name	Description	Version
74HC595D	-40 °C to +125 °C	SO16	plastic small outline package; 16 leads; body width 3.9 mm	SOT109-1
74HCT595D				
74HC595DB	-40 °C to +125 °C	SSOP16	plastic shrink small outline package; 16 leads; body width 5.3 mm	SOT338-1
74HCT595DB				
74HC595PW	-40 °C to +125 °C	TSSOP16	plastic thin shrink small outline package; 16 leads; body width 4.4 mm	SOT403-1
74HCT595PW				
74HC595BQ	-40 °C to +125 °C	DHVQFN16	plastic dual in-line compatible thermal enhanced very thin quad flat package; no leads; 16 terminals; body 2.5 × 3.5 × 0.85 mm	SOT763-1
74HCT595BQ				

## 5. Functional diagram

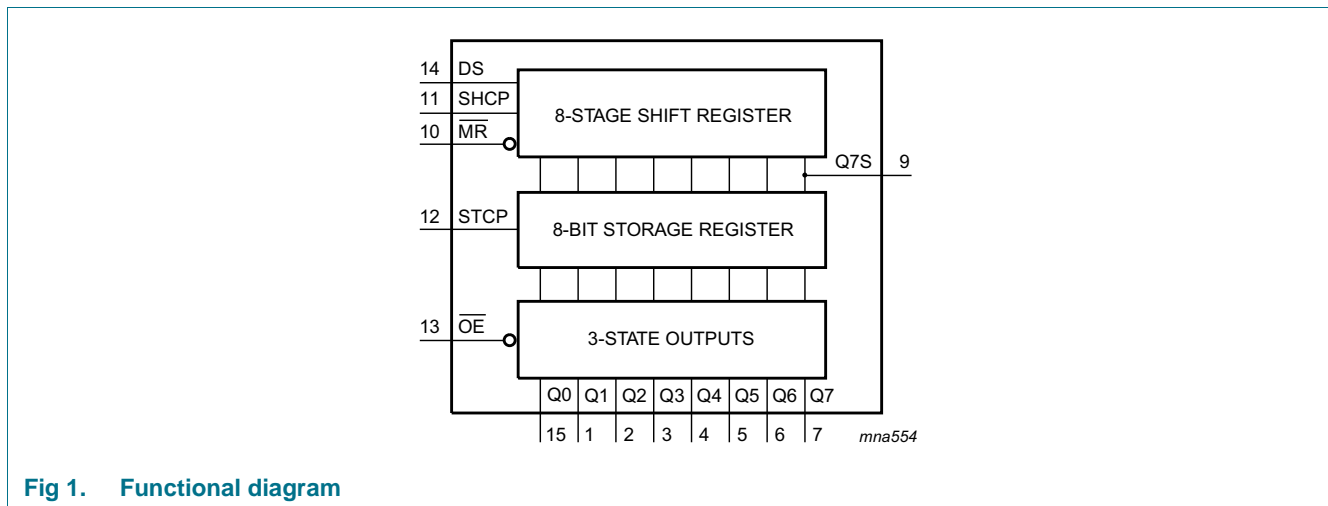

Fig 1. Functional diagram

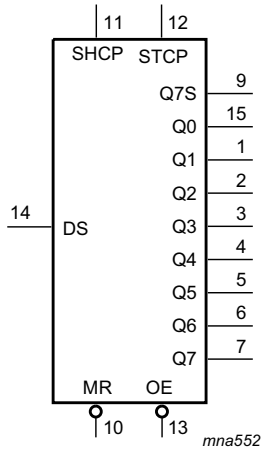

Fig 2. Logic symbol

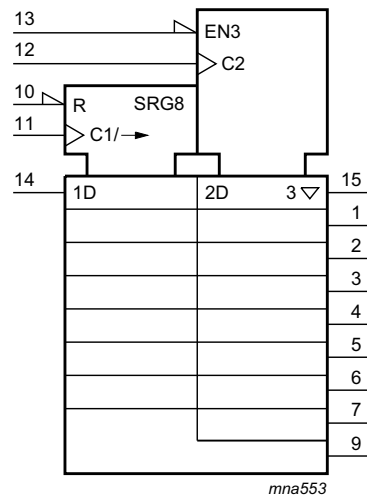

Fig 3. IEC logic symbol

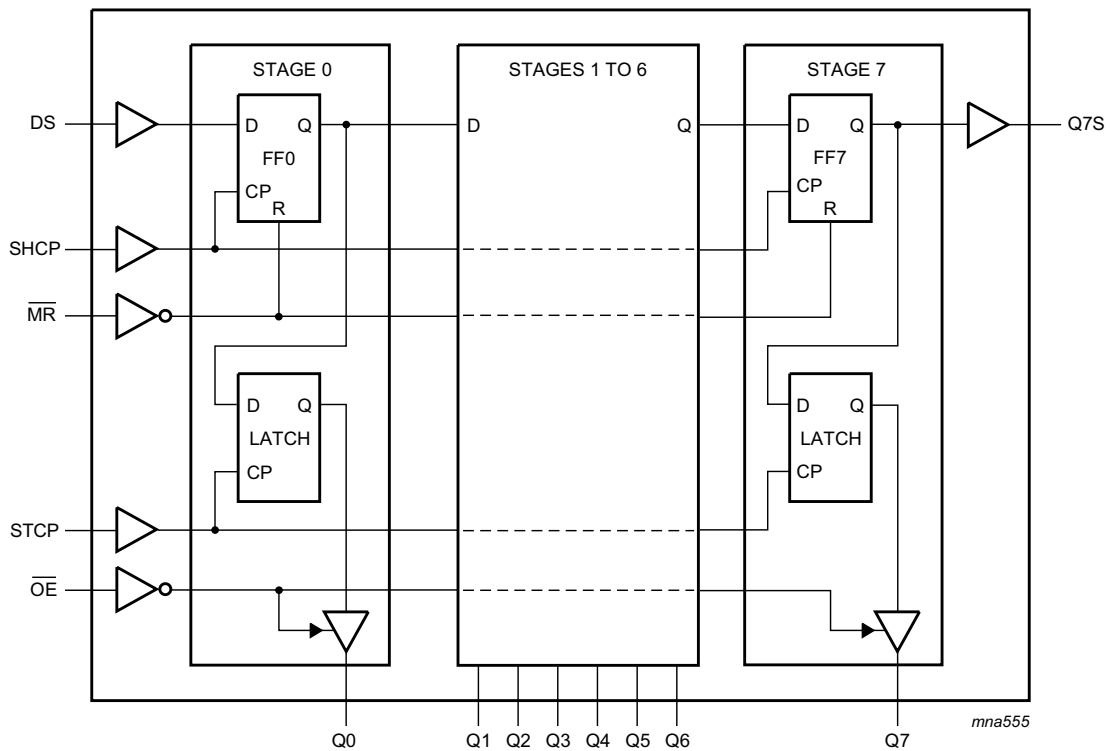
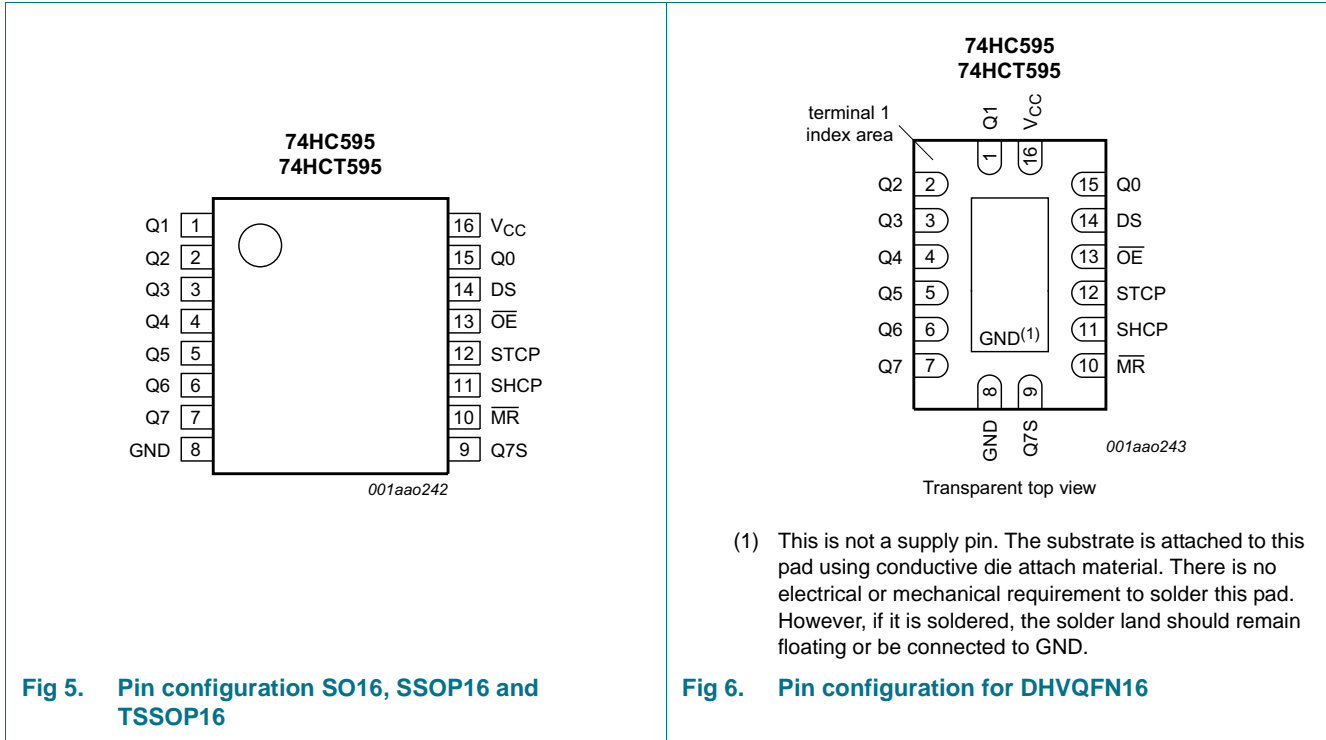

Fig 4. Logic diagram

6. Pinning information

6.1 Pinning



6.2 Pin description

Table 2. Pin description

Symbol	Pin	Description
Q0, Q1, Q2, Q3, Q4, Q5, Q6, Q7	15, 1, 2, 3, 4, 5, 6, 7	parallel data output
GND	8	ground (0 V)
Q7S	9	serial data output
MR	10	master reset (active LOW)
SHCP	11	shift register clock input
STCP	12	storage register clock input
OE	13	output enable input (active LOW)
DS	14	serial data input
Q0	15	parallel data output 0
V <sub>CC</sub>	16	supply voltage

## 7. Functional description

Table 3. Function table<sup>[1]</sup>

Control				Input	Output		Function
SHCP	STCP	$\overline{OE}$	$\overline{MR}$	DS	Q7S	Qn	
X	X	L	L	X	L	NC	a LOW-level on $\overline{MR}$ only affects the shift registers
X	↑	L	L	X	L	L	empty shift register loaded into storage register
X	X	H	L	X	L	Z	shift register clear; parallel outputs in high-impedance OFF-state
↑	X	L	H	H	Q6S	NC	logic HIGH-level shifted into shift register stage 0. Contents of all shift register stages shifted through, e.g. previous state of stage 6 (internal Q6S) appears on the serial output (Q7S).
X	↑	L	H	X	NC	QnS	contents of shift register stages (internal QnS) are transferred to the storage register and parallel output stages
↑	↑	L	H	X	Q6S	QnS	contents of shift register shifted through; previous contents of the shift register is transferred to the storage register and the parallel output stages

- [1] H = HIGH voltage state;  
 L = LOW voltage state;  
 ↑ = LOW-to-HIGH transition;  
 X = don't care;  
 NC = no change;  
 Z = high-impedance OFF-state.

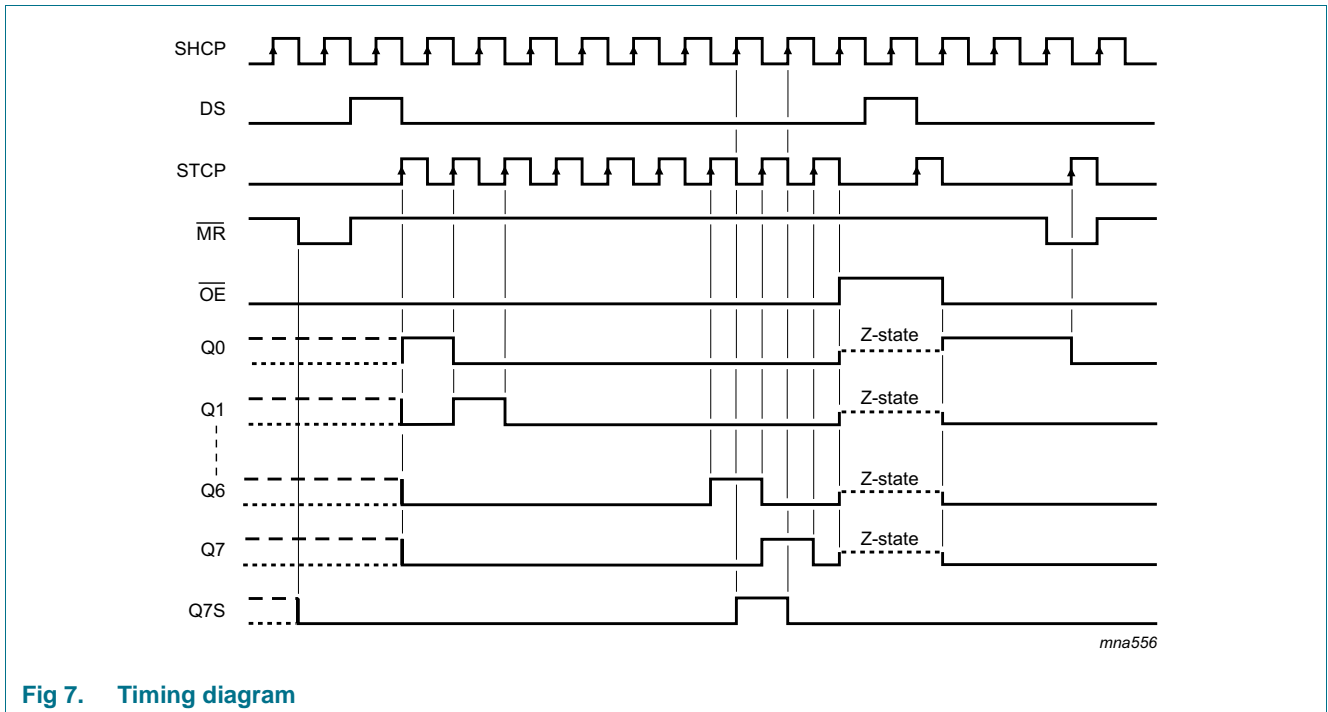

Fig 7. Timing diagram

## 8. Limiting values

**Table 4. Limiting values**

In accordance with the Absolute Maximum Rating System (IEC 60134). Voltages are referenced to GND (ground = 0 V).

Symbol	Parameter	Conditions	Min	Max	Unit
$V_{CC}$	supply voltage		-0.5	+7	V
$I_{IK}$	input clamping current	$V_I < -0.5\text{ V}$ or $V_I > V_{CC} + 0.5\text{ V}$	-	$\pm 20$	mA
$I_{OK}$	output clamping current	$V_O < -0.5\text{ V}$ or $V_O > V_{CC} + 0.5\text{ V}$	-	$\pm 20$	mA
$I_O$	output current	$V_O = -0.5\text{ V}$ to $(V_{CC} + 0.5\text{ V})$			
		pin Q7S	-	$\pm 25$	mA
		pins Qn	-	$\pm 35$	mA
$I_{CC}$	supply current		-	70	mA
$I_{GND}$	ground current		-70	-	mA
$T_{stg}$	storage temperature		-65	+150	°C
$P_{tot}$	total power dissipation	SO16 package <a href="#">[1]</a>	-	500	mW
		SSOP16 package <a href="#">[2]</a>	-	500	mW
		TSSOP16 package <a href="#">[2]</a>	-	500	mW
		DHVQFN16 package <a href="#">[3]</a>	-	500	mW

[1] For SO16 package:  $P_{tot}$  derates linearly with 8 mW/K above 70 °C.

[2] For SSOP16 and TSSOP16 packages:  $P_{tot}$  derates linearly with 5.5 mW/K above 60 °C.

[3] For DHVQFN16 package:  $P_{tot}$  derates linearly with 4.5 mW/K above 60 °C.

## 9. Recommended operating conditions

**Table 5. Recommended operating conditions**

Symbol	Parameter	Conditions	74HC595			74HCT595			Unit
			Min	Typ	Max	Min	Typ	Max	
$V_{CC}$	supply voltage		2.0	5.0	6.0	4.5	5.0	5.5	V
$V_I$	input voltage		0	-	$V_{CC}$	0	-	$V_{CC}$	V
$V_O$	output voltage		0	-	$V_{CC}$	0	-	$V_{CC}$	V
$\Delta t/\Delta V$	input transition rise and fall rate	$V_{CC} = 2.0\text{ V}$	-	-	625	-	-	-	ns/V
		$V_{CC} = 4.5\text{ V}$	-	1.67	139	-	1.67	139	ns/V
		$V_{CC} = 6.0\text{ V}$	-	-	83	-	-	-	ns/V
$T_{amb}$	ambient temperature		-40	+25	+125	-40	+25	+125	°C

### 10. Static characteristics

**Table 6. Static characteristics**

At recommended operating conditions; voltages are referenced to GND (ground = 0 V).

Symbol	Parameter	Conditions	-40 °C to +85 °C			-40 °C to +125 °C		Unit
			Min	Typ	Max	Min	Max	
<b>74HC595</b>								
V <sub>IH</sub>	HIGH-level input voltage	V <sub>CC</sub> = 2.0 V	1.5	1.2	-	1.5	-	V
		V <sub>CC</sub> = 4.5 V	3.15	2.4	-	3.15	-	V
		V <sub>CC</sub> = 6.0 V	4.2	3.2	-	4.2	-	V
V <sub>IL</sub>	LOW-level input voltage	V <sub>CC</sub> = 2.0 V	-	0.8	0.5	-	0.5	V
		V <sub>CC</sub> = 4.5 V	-	2.1	1.35	-	1.35	V
		V <sub>CC</sub> = 6.0 V	-	2.8	1.8	-	1.8	V
V <sub>OH</sub>	HIGH-level output voltage	V <sub>I</sub> = V <sub>IH</sub> or V <sub>IL</sub> all outputs						
		I <sub>O</sub> = -20 μA; V <sub>CC</sub> = 2.0 V	1.9	2.0	-	1.9	-	V
		I <sub>O</sub> = -20 μA; V <sub>CC</sub> = 4.5 V	4.4	4.5	-	4.4	-	V
		I <sub>O</sub> = -20 μA; V <sub>CC</sub> = 6.0 V	5.9	6.0	-	5.9	-	V
		Q7S output						
		I <sub>O</sub> = -4 mA; V <sub>CC</sub> = 4.5 V	3.84	4.32	-	3.7	-	V
		I <sub>O</sub> = -5.2 mA; V <sub>CC</sub> = 6.0 V	5.34	5.81	-	5.2	-	V
		Qn bus driver outputs						
		I <sub>O</sub> = -6 mA; V <sub>CC</sub> = 4.5 V	3.84	4.32	-	3.7	-	V
I <sub>O</sub> = -7.8 mA; V <sub>CC</sub> = 6.0 V	5.34	5.81	-	5.2	-	V		
V <sub>OL</sub>	LOW-level output voltage	V <sub>I</sub> = V <sub>IH</sub> or V <sub>IL</sub> all outputs						
		I <sub>O</sub> = 20 μA; V <sub>CC</sub> = 2.0 V	-	0	0.1	-	0.1	V
		I <sub>O</sub> = 20 μA; V <sub>CC</sub> = 4.5 V	-	0	0.1	-	0.1	V
		I <sub>O</sub> = 20 μA; V <sub>CC</sub> = 6.0 V	-	0	0.1	-	0.1	V
		Q7S output						
		I <sub>O</sub> = 4 mA; V <sub>CC</sub> = 4.5 V	-	0.15	0.33	-	0.4	V
		I <sub>O</sub> = 5.2 mA; V <sub>CC</sub> = 6.0 V	-	0.16	0.33	-	0.4	V
		Qn bus driver outputs						
		I <sub>O</sub> = 6 mA; V <sub>CC</sub> = 4.5 V	-	0.15	0.33	-	0.4	V
I <sub>O</sub> = 7.8 mA; V <sub>CC</sub> = 6.0 V	-	0.16	0.33	-	0.4	V		
I <sub>I</sub>	input leakage current	V <sub>I</sub> = V <sub>CC</sub> or GND; V <sub>CC</sub> = 6.0 V	-	-	±1.0	-	±1.0	μA
I <sub>OZ</sub>	OFF-state output current	V <sub>I</sub> = V <sub>IH</sub> or V <sub>IL</sub> ; V <sub>CC</sub> = 6.0 V; V <sub>O</sub> = V <sub>CC</sub> or GND	-	-	±5.0	-	±10	μA
I <sub>CC</sub>	supply current	V <sub>I</sub> = V <sub>CC</sub> or GND; I <sub>O</sub> = 0 A; V <sub>CC</sub> = 6.0 V	-	-	80	-	160	μA
C <sub>I</sub>	input capacitance		-	3.5	-	-	-	pF

**Table 6. Static characteristics ...continued**

At recommended operating conditions; voltages are referenced to GND (ground = 0 V).

Symbol	Parameter	Conditions	-40 °C to +85 °C			-40 °C to +125 °C		Unit
			Min	Typ	Max	Min	Max	
<b>74HCT595</b>								
V <sub>IH</sub>	HIGH-level input voltage	V <sub>CC</sub> = 4.5 V to 5.5 V	2.0	1.6	-	2.0	-	V
V <sub>IL</sub>	LOW-level input voltage	V <sub>CC</sub> = 4.5 V to 5.5 V	-	1.2	0.8	-	0.8	V
V <sub>OH</sub>	HIGH-level output voltage	V <sub>I</sub> = V <sub>IH</sub> or V <sub>IL</sub> ; V <sub>CC</sub> = 4.5 V						
		all outputs						
		I <sub>O</sub> = -20 μA	4.4	4.5	-	4.4	-	V
		Q7S output						
		I <sub>O</sub> = -4 mA	3.84	4.32	-	3.7	-	V
V <sub>OL</sub>	LOW-level output voltage	V <sub>I</sub> = V <sub>IH</sub> or V <sub>IL</sub> ; V <sub>CC</sub> = 4.5 V						
		all outputs						
		I <sub>O</sub> = 20 μA	-	0	0.1	-	0.1	V
		Q7S output						
		I <sub>O</sub> = 4.0 mA	-	0.15	0.33	-	0.4	V
I <sub>I</sub>	input leakage current	V <sub>I</sub> = V <sub>CC</sub> or GND; V <sub>CC</sub> = 5.5 V	-	-	±1.0	-	±1.0	μA
I <sub>OZ</sub>	OFF-state output current	V <sub>I</sub> = V <sub>IH</sub> or V <sub>IL</sub> ; V <sub>CC</sub> = 5.5 V; V <sub>O</sub> = V <sub>CC</sub> or GND	-	-	±5.0	-	±10	μA
I <sub>CC</sub>	supply current	V <sub>I</sub> = V <sub>CC</sub> or GND; I <sub>O</sub> = 0 A; V <sub>CC</sub> = 5.5 V	-	-	80	-	160	μA
ΔI <sub>CC</sub>	additional supply current	per input pin; I <sub>O</sub> = 0 A; V <sub>I</sub> = V <sub>CC</sub> - 2.1 V; other inputs at V <sub>CC</sub> or GND; V <sub>CC</sub> = 4.5 V to 5.5 V						
		pins MR, SHCP, STCP, OE	-	150	675	-	735	μA
		pin DS	-	25	113	-	123	μA
C <sub>I</sub>	input capacitance		-	3.5	-	-	-	pF



## 11. Dynamic characteristics

**Table 7. Dynamic characteristics**

Voltages are referenced to GND (ground = 0 V); for test circuit see [Figure 13](#).

Symbol	Parameter	Conditions	25 °C			-40 °C to +85 °C		-40 °C to +125 °C		Unit
			Min	Typ <sup>[1]</sup>	Max	Min	Max	Min	Max	
<b>74HC595</b>										
t <sub>pd</sub>	propagation delay	SHCP to Q7S; see <a href="#">Figure 8</a> <sup>[2]</sup>								
		V <sub>CC</sub> = 2 V	-	52	160	-	200	-	240	ns
		V <sub>CC</sub> = 4.5 V	-	19	32	-	40	-	48	ns
		V <sub>CC</sub> = 6 V	-	15	27	-	34	-	41	ns
		STCP to Qn; see <a href="#">Figure 9</a> <sup>[2]</sup>								
		V <sub>CC</sub> = 2 V	-	55	175	-	220	-	265	ns
		V <sub>CC</sub> = 4.5 V	-	20	35	-	44	-	53	ns
		V <sub>CC</sub> = 6 V	-	16	30	-	37	-	45	ns
		MR to Q7S; see <a href="#">Figure 11</a> <sup>[3]</sup>								
		V <sub>CC</sub> = 2 V	-	47	175	-	220	-	265	ns
V <sub>CC</sub> = 4.5 V	-	17	35	-	44	-	53	ns		
V <sub>CC</sub> = 6 V	-	14	30	-	37	-	45	ns		
t <sub>en</sub>	enable time	OE to Qn; see <a href="#">Figure 12</a> <sup>[4]</sup>								
		V <sub>CC</sub> = 2 V	-	47	150	-	190	-	225	ns
		V <sub>CC</sub> = 4.5 V	-	17	30	-	38	-	45	ns
		V <sub>CC</sub> = 6 V	-	14	26	-	33	-	38	ns
t <sub>dis</sub>	disable time	OE to Qn; see <a href="#">Figure 12</a> <sup>[5]</sup>								
		V <sub>CC</sub> = 2 V	-	41	150	-	190	-	225	ns
		V <sub>CC</sub> = 4.5 V	-	15	30	-	38	-	45	ns
		V <sub>CC</sub> = 6 V	-	12	27	-	33	-	38	ns
t <sub>w</sub>	pulse width	SHCP HIGH or LOW; see <a href="#">Figure 8</a>								
		V <sub>CC</sub> = 2 V	75	17	-	95	-	110	-	ns
		V <sub>CC</sub> = 4.5 V	15	6	-	19	-	22	-	ns
		V <sub>CC</sub> = 6 V	13	5	-	16	-	19	-	ns
		STCP HIGH or LOW; see <a href="#">Figure 9</a>								
		V <sub>CC</sub> = 2 V	75	11	-	95	-	110	-	ns
		V <sub>CC</sub> = 4.5 V	15	4	-	19	-	22	-	ns
		V <sub>CC</sub> = 6 V	13	3	-	16	-	19	-	ns
		MR LOW; see <a href="#">Figure 11</a>								
		V <sub>CC</sub> = 2 V	75	17	-	95	-	110	-	ns
		V <sub>CC</sub> = 4.5 V	15	6	-	19	-	22	-	ns
		V <sub>CC</sub> = 6 V	13	5	-	16	-	19	-	ns

antowka.ru

**Table 7. Dynamic characteristics ...continued**Voltages are referenced to GND (ground = 0 V); for test circuit see [Figure 13](#).

Symbol	Parameter	Conditions	25 °C			-40 °C to +85 °C		-40 °C to +125 °C		Unit
			Min	Typ <sup>[1]</sup>	Max	Min	Max	Min	Max	
t <sub>su</sub>	set-up time	DS to SHCP; see <a href="#">Figure 9</a>								
		V <sub>CC</sub> = 2 V	50	11	-	65	-	75	-	ns
		V <sub>CC</sub> = 4.5 V	10	4	-	13	-	15	-	ns
		V <sub>CC</sub> = 6 V	9	3	-	11	-	13	-	ns
		SHCP to STCP; see <a href="#">Figure 10</a>								
		V <sub>CC</sub> = 2 V	75	22	-	95	-	110	-	ns
		V <sub>CC</sub> = 4.5 V	15	8	-	19	-	22	-	ns
V <sub>CC</sub> = 6 V	13	7	-	16	-	19	-	ns		
t <sub>h</sub>	hold time	DS to SHCP; see <a href="#">Figure 10</a>								
		V <sub>CC</sub> = 2 V	3	-6	-	3	-	3	-	ns
		V <sub>CC</sub> = 4.5 V	3	-2	-	3	-	3	-	ns
		V <sub>CC</sub> = 6 V	3	-2	-	3	-	3	-	ns
t <sub>rec</sub>	recovery time	MR to SHCP; see <a href="#">Figure 11</a>								
		V <sub>CC</sub> = 2 V	50	-19	-	65	-	75	-	ns
		V <sub>CC</sub> = 4.5 V	10	-7	-	13	-	15	-	ns
		V <sub>CC</sub> = 6 V	9	-6	-	11	-	13	-	ns
f <sub>max</sub>	maximum frequency	SHCP or STCP; see <a href="#">Figure 8</a> and <a href="#">9</a>								
		V <sub>CC</sub> = 2 V	9	30	-	4.8	-	4	-	MHz
		V <sub>CC</sub> = 4.5 V	30	91	-	24	-	20	-	MHz
		V <sub>CC</sub> = 6 V	35	108	-	28	-	24	-	MHz
C <sub>PD</sub>	power dissipation capacitance	f <sub>i</sub> = 1 MHz; V <sub>I</sub> = GND to V <sub>CC</sub> <a href="#">[6][7]</a>	-	115	-	-	-	-	-	pF

**Table 7. Dynamic characteristics ...continued**

*Voltages are referenced to GND (ground = 0 V); for test circuit see [Figure 13](#).*

Symbol	Parameter	Conditions	25 °C			–40 °C to +85 °C		–40 °C to +125 °C		Unit
			Min	Typ <sup>[1]</sup>	Max	Min	Max	Min	Max	
<b>74HCT595; V<sub>CC</sub> = 4.5 V to 5.5 V</b>										
t <sub>pd</sub>	propagation delay	SHCP to Q7S; see <a href="#">Figure 8</a> <sup>[2]</sup>	-	25	42	-	53	-	63	ns
		STCP to Qn; see <a href="#">Figure 9</a> <sup>[2]</sup>	-	24	40	-	50	-	60	ns
		$\overline{\text{MR}}$ to Q7S; see <a href="#">Figure 11</a> <sup>[3]</sup>	-	23	40	-	50	-	60	ns
t <sub>en</sub>	enable time	$\overline{\text{OE}}$ to Qn; see <a href="#">Figure 12</a> <sup>[4]</sup>	-	21	35	-	44	-	53	ns
t <sub>dis</sub>	disable time	$\overline{\text{OE}}$ to Qn; see <a href="#">Figure 12</a> <sup>[5]</sup>	-	18	30	-	38	-	45	ns
t <sub>w</sub>	pulse width	SHCP HIGH or LOW; see <a href="#">Figure 8</a>	16	6	-	20	-	24	-	ns
		STCP HIGH or LOW; see <a href="#">Figure 9</a>	16	5	-	20	-	24	-	ns
		$\overline{\text{MR}}$ LOW; see <a href="#">Figure 11</a>	20	8	-	25	-	30	-	ns
t <sub>su</sub>	set-up time	DS to SHCP; see <a href="#">Figure 9</a>	16	5	-	20	-	24	-	ns
		SHCP to STCP; see <a href="#">Figure 10</a>	16	8	-	20	-	24	-	ns
t <sub>h</sub>	hold time	DS to SHCP; see <a href="#">Figure 10</a>	3	-2	-	3	-	3	-	ns
t <sub>rec</sub>	recovery time	$\overline{\text{MR}}$ to SHCP; see <a href="#">Figure 11</a>	10	-7	-	13	-	15	-	ns
f <sub>max</sub>	maximum frequency	SHCP and STCP; see <a href="#">Figure 8</a> and <a href="#">9</a>	30	52	-	24	-	20	-	MHz
C <sub>PD</sub>	power dissipation capacitance	f <sub>i</sub> = 1 MHz; <sup>[6]</sup> V <sub>I</sub> = GND to V <sub>CC</sub> – 1.5 V <sup>[7]</sup>	-	130	-	-	-	-	-	pF

- [1] Typical values are measured at nominal supply voltage.
- [2] t<sub>pd</sub> is the same as t<sub>PHL</sub> and t<sub>PLH</sub>.
- [3] t<sub>pd</sub> is the same as t<sub>PHL</sub> only.
- [4] t<sub>en</sub> is the same as t<sub>PZL</sub> and t<sub>PZH</sub>.
- [5] t<sub>dis</sub> is the same as t<sub>PLZ</sub> and t<sub>PHZ</sub>.
- [6] C<sub>PD</sub> is used to determine the dynamic power dissipation (P<sub>D</sub> in μW).  
 $P_D = C_{PD} \times V_{CC}^2 \times f_i + \Sigma(C_L \times V_{CC}^2 \times f_o)$  where:  
 f<sub>i</sub> = input frequency in MHz;  
 f<sub>o</sub> = output frequency in MHz;  
 $\Sigma(C_L \times V_{CC}^2 \times f_o)$  = sum of outputs;  
 C<sub>L</sub> = output load capacitance in pF;  
 V<sub>CC</sub> = supply voltage in V.
- [7] All 9 outputs switching.

12. Waveforms

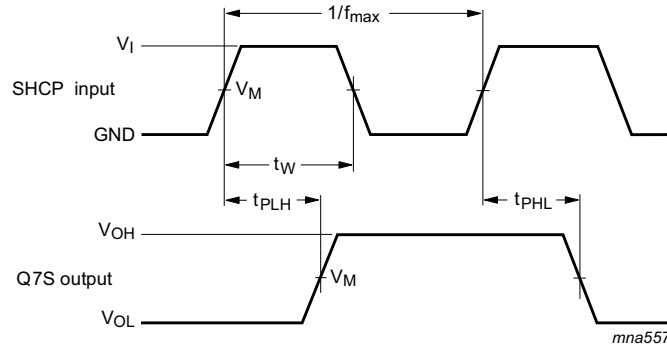

Measurement points are given in [Table 8](#).  
 V<sub>OL</sub> and V<sub>OH</sub> are typical output voltage levels that occur with the output load.

**Fig 8. Shift clock pulse, maximum frequency and input to output propagation delays**

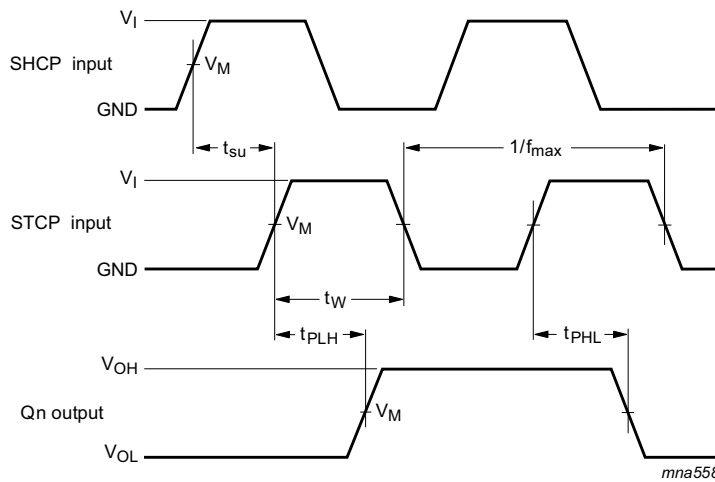

Measurement points are given in [Table 8](#).  
 V<sub>OL</sub> and V<sub>OH</sub> are typical output voltage levels that occur with the output load.

**Fig 9. Storage clock to output propagation delays**

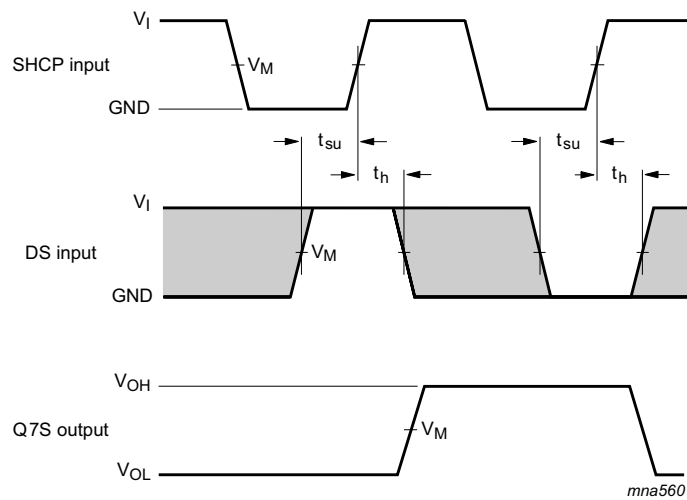

Measurement points are given in [Table 8](#).

The shaded areas indicate when the input is permitted to change for predictable output performance.

$V_{OL}$  and  $V_{OH}$  are typical output voltage levels that occur with the output load.

**Fig 10. Data set-up and hold times**

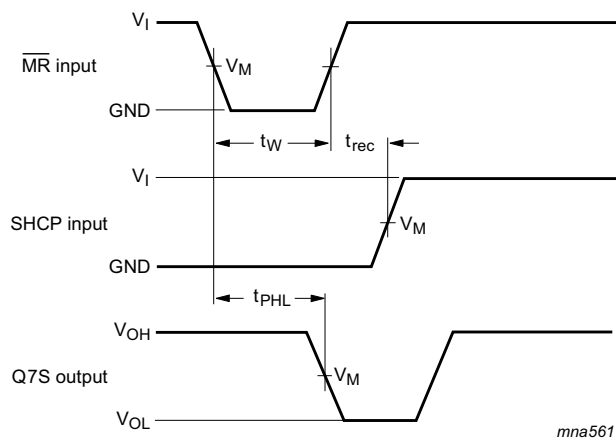

Measurement points are given in [Table 8](#).

$V_{OL}$  and  $V_{OH}$  are typical output voltage levels that occur with the output load.

**Fig 11. Master reset to output propagation delays**

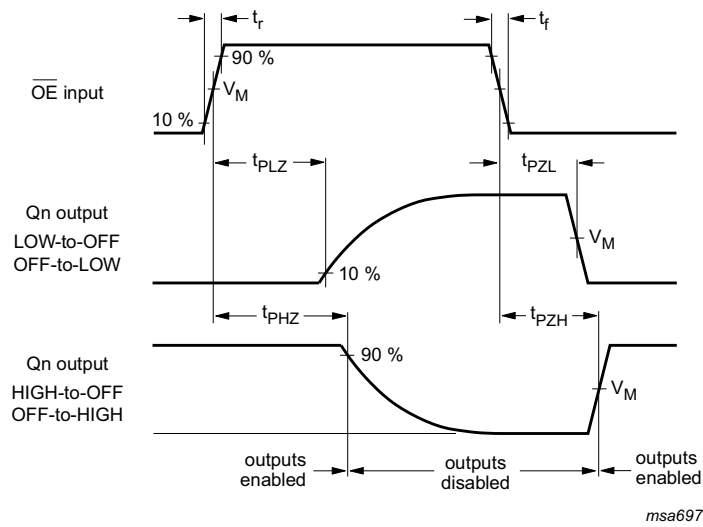

Measurement points are given in [Table 8](#).  
 $V_{OL}$  and  $V_{OH}$  are typical output voltage levels that occur with the output load.

**Fig 12. Enable and disable times**

**Table 8. Measurement points**

Type	Input	Output
	$V_M$	$V_M$
74HC595	$0.5V_{CC}$	$0.5V_{CC}$
74HCT595	1.3 V	1.3 V

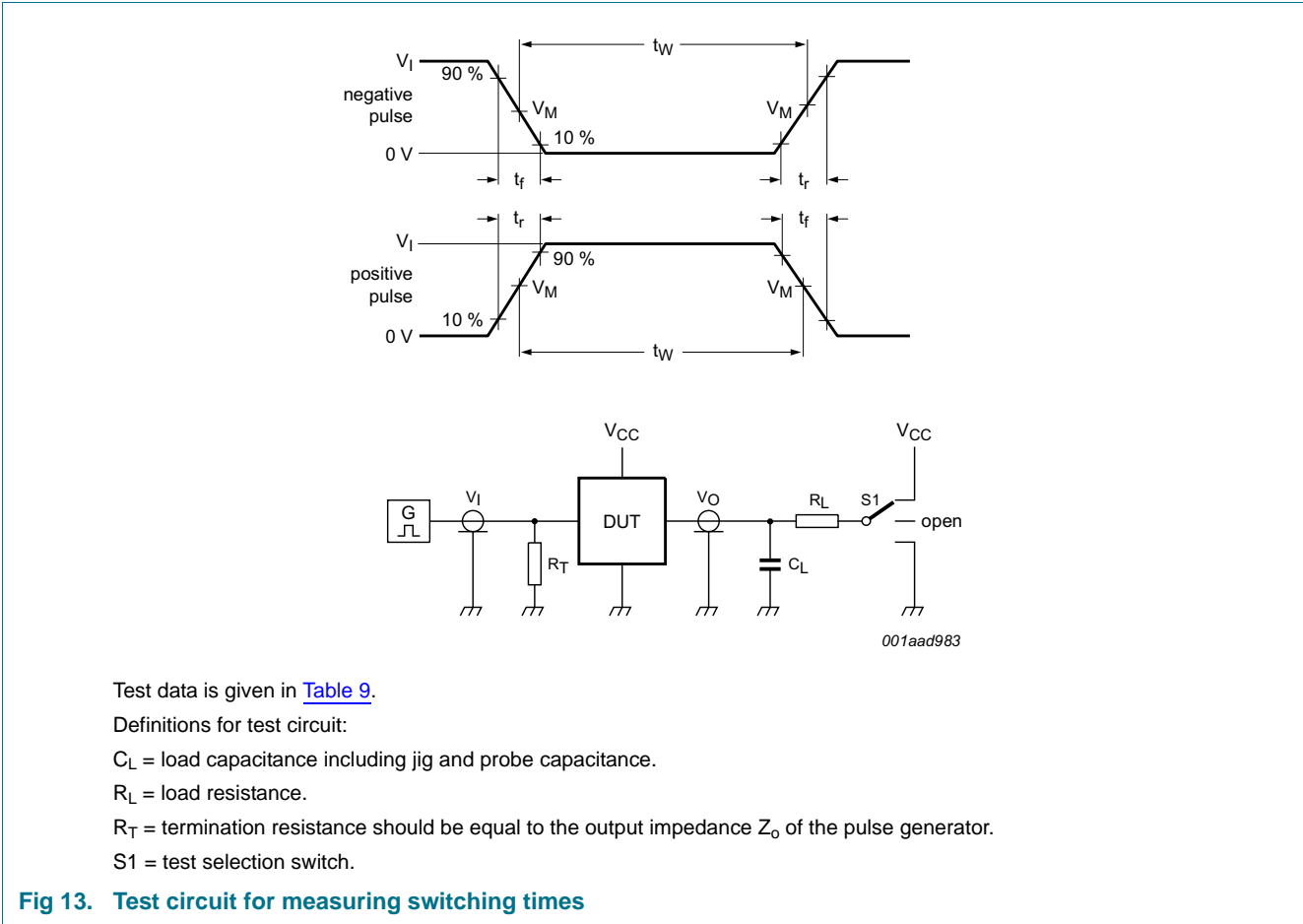

Table 9. Test data

Type	Input		Load		S1 position		
	$V_I$	$t_r, t_f$	$C_L$	$R_L$	$t_{PHL}, t_{PLH}$	$t_{PZH}, t_{PHZ}$	$t_{PZL}, t_{PLZ}$
74HC595	$V_{CC}$	6 ns	50 pF	1 k $\Omega$	open	GND	$V_{CC}$
74HCT595	3 V	6 ns	50 pF	1 k $\Omega$	open	GND	$V_{CC}$

13. Package outline

SO16: plastic small outline package; 16 leads; body width 3.9 mm

SOT109-1

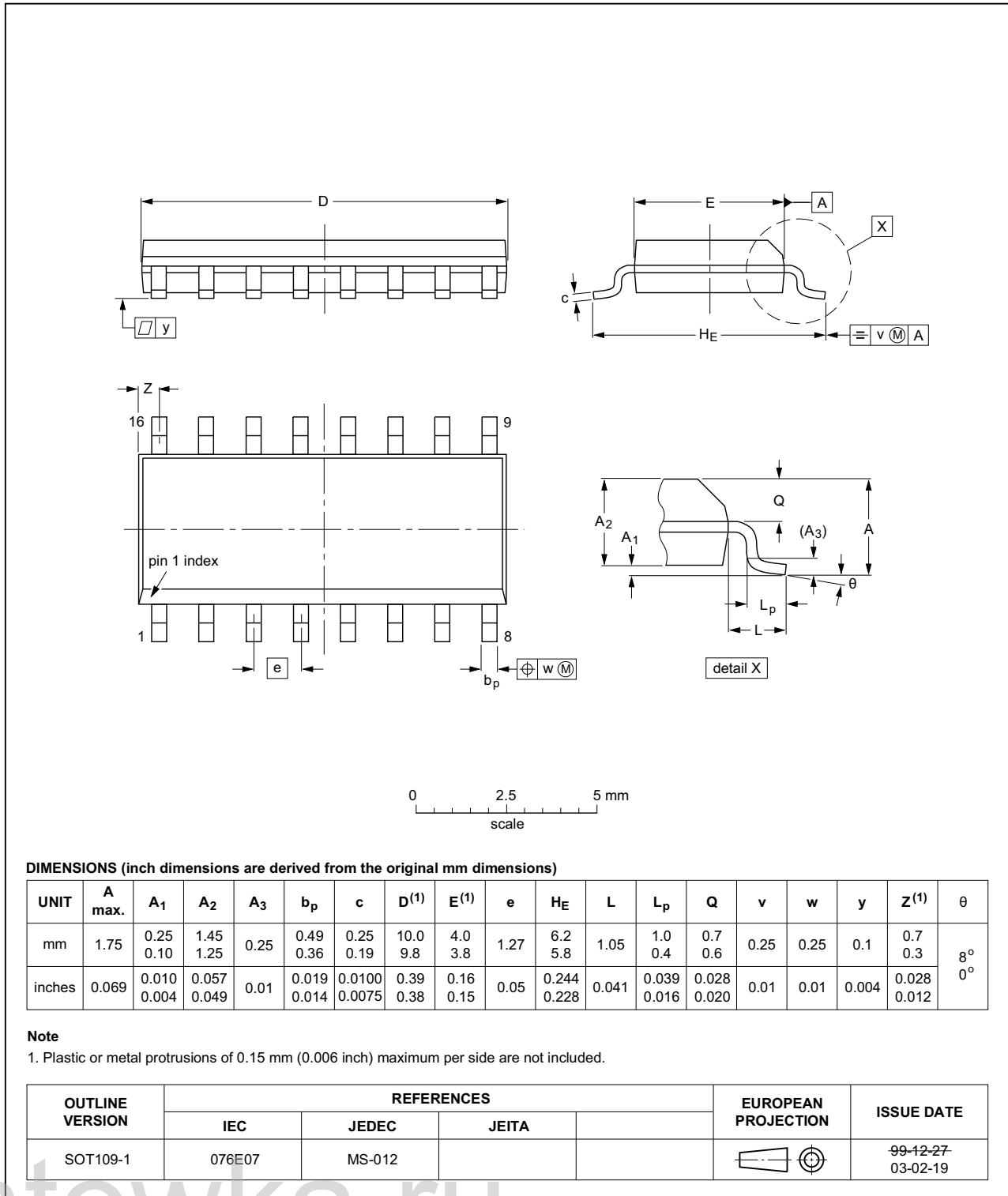

Fig 14. Package outline SOT109-1 (SO16)



SSOP16: plastic shrink small outline package; 16 leads; body width 5.3 mm

SOT338-1

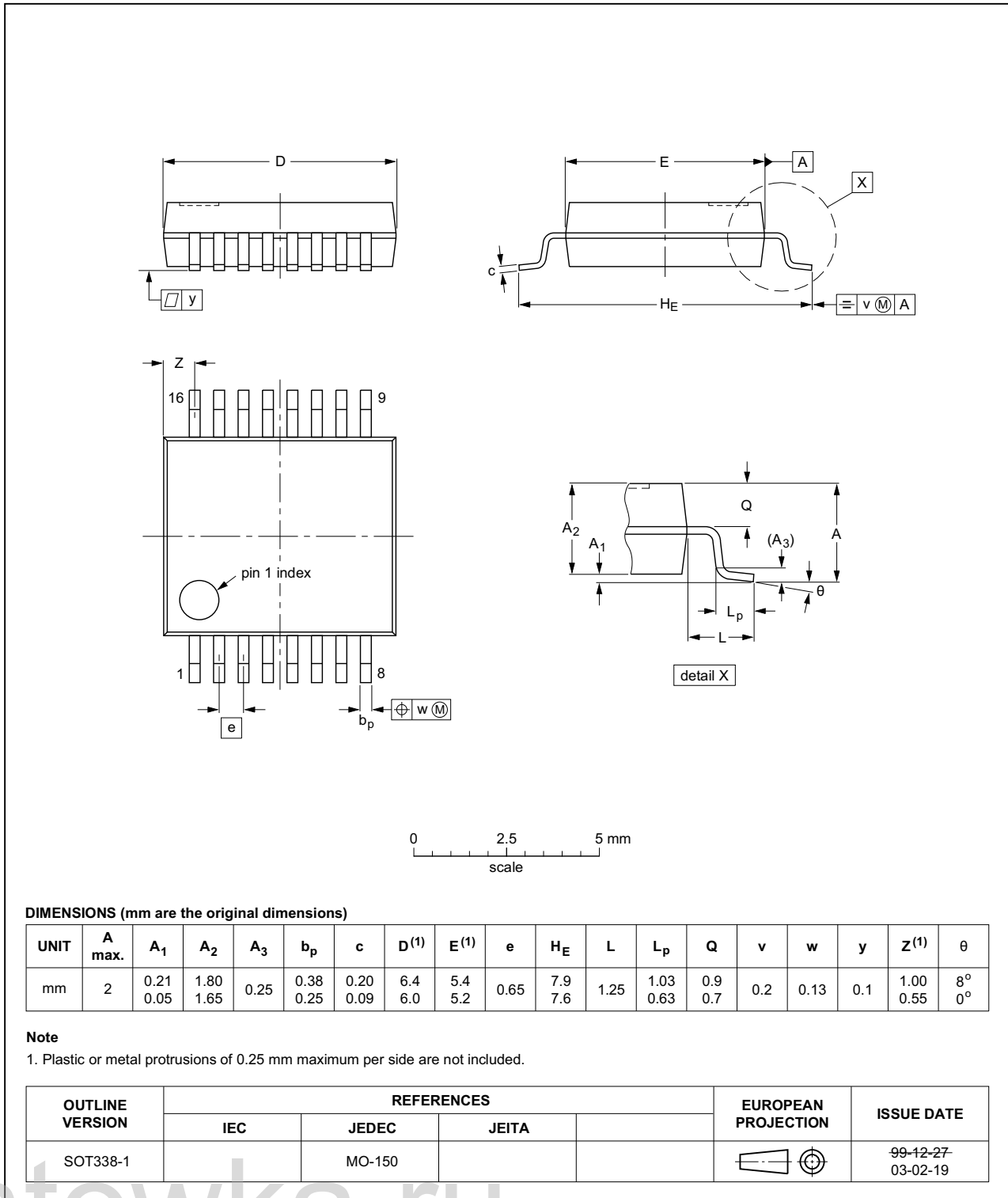

Fig 15. Package outline SOT338-1 (SSOP16)

TSSOP16: plastic thin shrink small outline package; 16 leads; body width 4.4 mm

SOT403-1

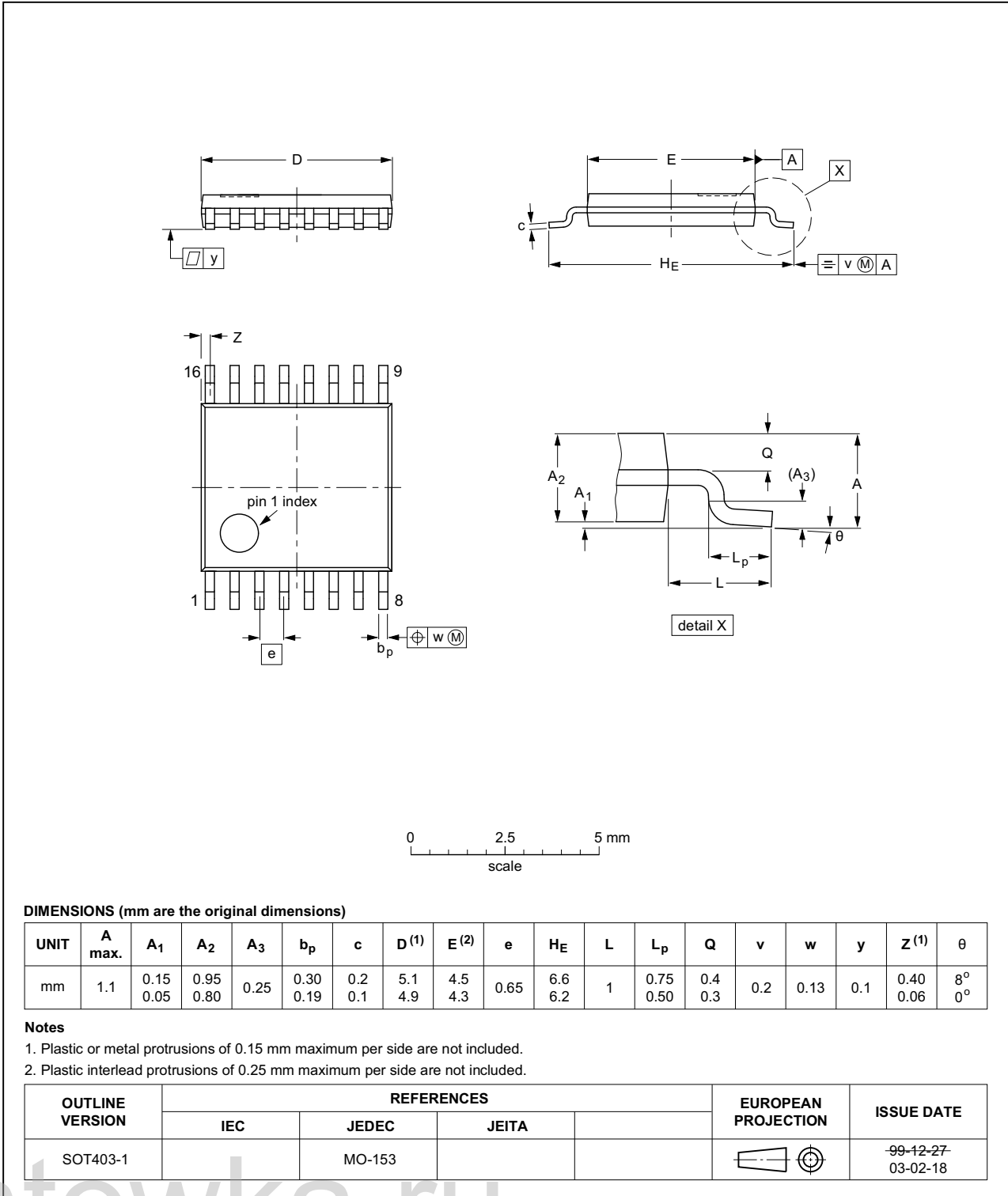

Fig 16. Package outline SOT403-1 (TSSOP16)

DHVQFN16: plastic dual in-line compatible thermal enhanced very thin quad flat package; no leads; 16 terminals; body 2.5 x 3.5 x 0.85 mm

SOT763-1

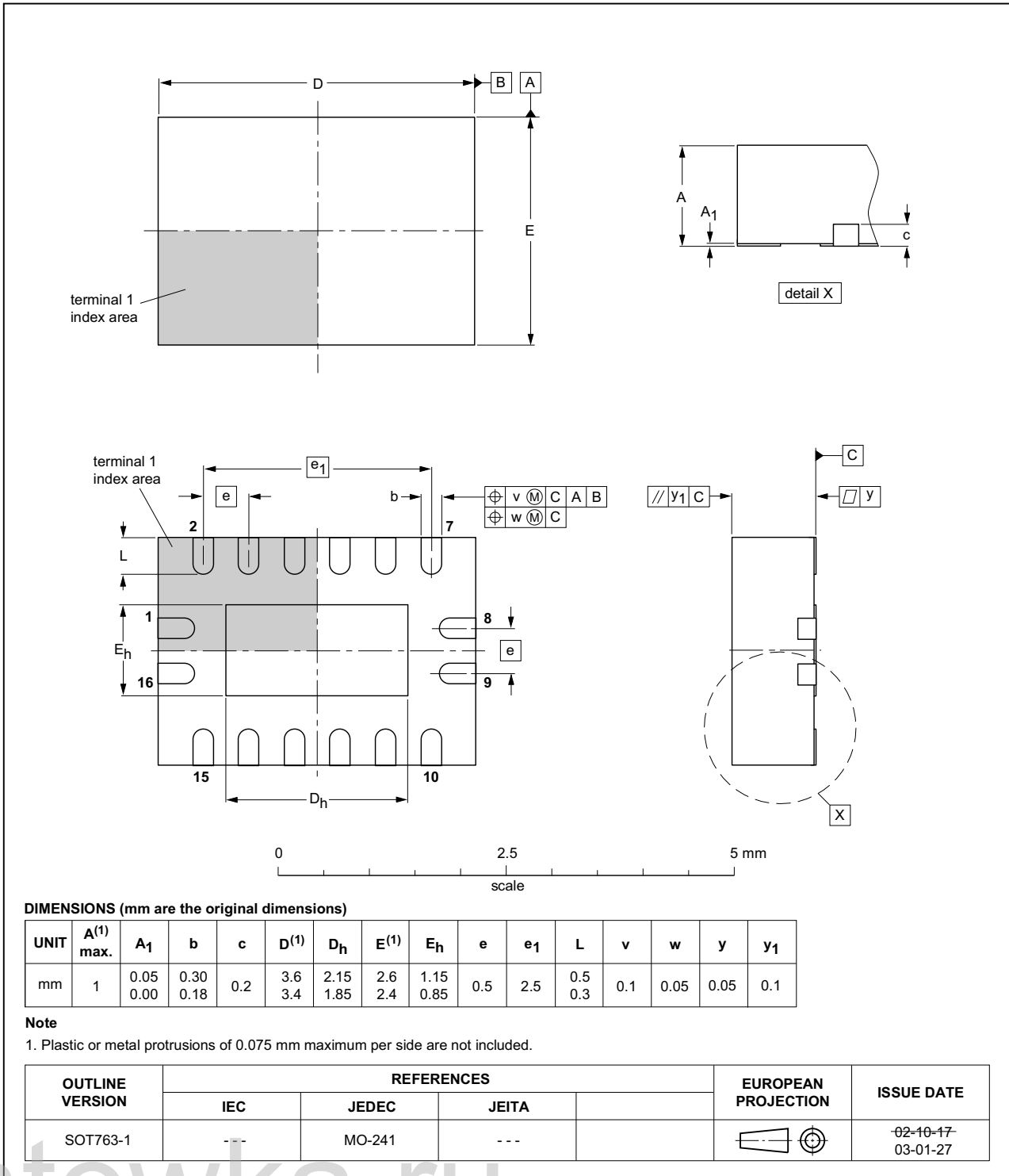

Fig 17. Package outline SOT763-1 (DHVQFN16)

## 14. Abbreviations

Table 10. Abbreviations

Acronym	Abbreviation
CMOS	Complementary Metal Oxide Semiconductor
DUT	Device Under Test
ESD	ElectroStatic Discharge
HBM	Human Body Model
LSTTL	Low-power Schottky Transistor-Transistor Logic
MM	Machine Model

## 15. Revision history

Table 11. Revision history

Document ID	Release date	Data sheet status	Change notice	Supersedes
74HC_HCT595 v.8	20160225	Product data sheet	-	74HC_HCT595 v.7
Modifications:	<ul style="list-style-type: none"> <li>Type numbers 74HC595N and 74HCT595N (SOT38-4) removed.</li> </ul>			
74HC_HCT595 v.7	20150126	Product data sheet	-	74HC_HCT595 v.6
Modifications:	<ul style="list-style-type: none"> <li><a href="#">Table 7</a>: Power dissipation capacitance condition for 74HCT595 is corrected.</li> </ul>			
74HC_HCT595 v.6	20111212	Product data sheet	-	74HC_HCT595 v.5
Modifications:	<ul style="list-style-type: none"> <li>Legal pages updated.</li> </ul>			
74HC_HCT595 v.5	20110628	Product data sheet	-	74HC_HCT595 v.4
74HC_HCT595 v.4	20030604	Product specification	-	74HC_HCT595_CNV v.3
74HC_HCT595_CNV v.3	19980604	Product specification	-	-

## 16. Legal information

### 16.1 Data sheet status

Document status <sup>[1][2]</sup>	Product status <sup>[3]</sup>	Definition
Objective [short] data sheet	Development	This document contains data from the objective specification for product development.
Preliminary [short] data sheet	Qualification	This document contains data from the preliminary specification.
Product [short] data sheet	Production	This document contains the product specification.

[1] Please consult the most recently issued document before initiating or completing a design.

[2] The term 'short data sheet' is explained in section "Definitions".

[3] The product status of device(s) described in this document may have changed since this document was published and may differ in case of multiple devices. The latest product status information is available on the Internet at URL <http://www.nxp.com>.

### 16.2 Definitions

**Draft** — The document is a draft version only. The content is still under internal review and subject to formal approval, which may result in modifications or additions. NXP Semiconductors does not give any representations or warranties as to the accuracy or completeness of information included herein and shall have no liability for the consequences of use of such information.

**Short data sheet** — A short data sheet is an extract from a full data sheet with the same product type number(s) and title. A short data sheet is intended for quick reference only and should not be relied upon to contain detailed and full information. For detailed and full information see the relevant full data sheet, which is available on request via the local NXP Semiconductors sales office. In case of any inconsistency or conflict with the short data sheet, the full data sheet shall prevail.

**Product specification** — The information and data provided in a Product data sheet shall define the specification of the product as agreed between NXP Semiconductors and its customer, unless NXP Semiconductors and customer have explicitly agreed otherwise in writing. In no event however, shall an agreement be valid in which the NXP Semiconductors product is deemed to offer functions and qualities beyond those described in the Product data sheet.

### 16.3 Disclaimers

**Limited warranty and liability** — Information in this document is believed to be accurate and reliable. However, NXP Semiconductors does not give any representations or warranties, expressed or implied, as to the accuracy or completeness of such information and shall have no liability for the consequences of use of such information. NXP Semiconductors takes no responsibility for the content in this document if provided by an information source outside of NXP Semiconductors.

In no event shall NXP Semiconductors be liable for any indirect, incidental, punitive, special or consequential damages (including - without limitation - lost profits, lost savings, business interruption, costs related to the removal or replacement of any products or rework charges) whether or not such damages are based on tort (including negligence), warranty, breach of contract or any other legal theory.

Notwithstanding any damages that customer might incur for any reason whatsoever, NXP Semiconductors' aggregate and cumulative liability towards customer for the products described herein shall be limited in accordance with the *Terms and conditions of commercial sale* of NXP Semiconductors.

**Right to make changes** — NXP Semiconductors reserves the right to make changes to information published in this document, including without limitation specifications and product descriptions, at any time and without notice. This document supersedes and replaces all information supplied prior to the publication hereof.

**Suitability for use** — NXP Semiconductors products are not designed, authorized or warranted to be suitable for use in life support, life-critical or safety-critical systems or equipment, nor in applications where failure or malfunction of an NXP Semiconductors product can reasonably be expected to result in personal injury, death or severe property or environmental damage. NXP Semiconductors and its suppliers accept no liability for inclusion and/or use of NXP Semiconductors products in such equipment or applications and therefore such inclusion and/or use is at the customer's own risk.

**Applications** — Applications that are described herein for any of these products are for illustrative purposes only. NXP Semiconductors makes no representation or warranty that such applications will be suitable for the specified use without further testing or modification.

Customers are responsible for the design and operation of their applications and products using NXP Semiconductors products, and NXP Semiconductors accepts no liability for any assistance with applications or customer product design. It is customer's sole responsibility to determine whether the NXP Semiconductors product is suitable and fit for the customer's applications and products planned, as well as for the planned application and use of customer's third party customer(s). Customers should provide appropriate design and operating safeguards to minimize the risks associated with their applications and products.

NXP Semiconductors does not accept any liability related to any default, damage, costs or problem which is based on any weakness or default in the customer's applications or products, or the application or use by customer's third party customer(s). Customer is responsible for doing all necessary testing for the customer's applications and products using NXP Semiconductors products in order to avoid a default of the applications and the products or of the application or use by customer's third party customer(s). NXP does not accept any liability in this respect.

**Limiting values** — Stress above one or more limiting values (as defined in the Absolute Maximum Ratings System of IEC 60134) will cause permanent damage to the device. Limiting values are stress ratings only and (proper) operation of the device at these or any other conditions above those given in the Recommended operating conditions section (if present) or the Characteristics sections of this document is not warranted. Constant or repeated exposure to limiting values will permanently and irreversibly affect the quality and reliability of the device.

**Terms and conditions of commercial sale** — NXP Semiconductors products are sold subject to the general terms and conditions of commercial sale, as published at <http://www.nxp.com/profile/terms>, unless otherwise agreed in a valid written individual agreement. In case an individual agreement is concluded only the terms and conditions of the respective agreement shall apply. NXP Semiconductors hereby expressly objects to applying the customer's general terms and conditions with regard to the purchase of NXP Semiconductors products by customer.

**No offer to sell or license** — Nothing in this document may be interpreted or construed as an offer to sell products that is open for acceptance or the grant, conveyance or implication of any license under any copyrights, patents or other industrial or intellectual property rights.

**Export control** — This document as well as the item(s) described herein may be subject to export control regulations. Export might require a prior authorization from competent authorities.

**Non-automotive qualified products** — Unless this data sheet expressly states that this specific NXP Semiconductors product is automotive qualified, the product is not suitable for automotive use. It is neither qualified nor tested in accordance with automotive testing or application requirements. NXP Semiconductors accepts no liability for inclusion and/or use of non-automotive qualified products in automotive equipment or applications.

In the event that customer uses the product for design-in and use in automotive applications to automotive specifications and standards, customer (a) shall use the product without NXP Semiconductors' warranty of the product for such automotive applications, use and specifications, and (b) whenever customer uses the product for automotive applications beyond

NXP Semiconductors' specifications such use shall be solely at customer's own risk, and (c) customer fully indemnifies NXP Semiconductors for any liability, damages or failed product claims resulting from customer design and use of the product for automotive applications beyond NXP Semiconductors' standard warranty and NXP Semiconductors' product specifications.

**Translations** — A non-English (translated) version of a document is for reference only. The English version shall prevail in case of any discrepancy between the translated and English versions.

## 16.4 Trademarks

Notice: All referenced brands, product names, service names and trademarks are the property of their respective owners.

## 17. Contact information

For more information, please visit: <http://www.nxp.com>

For sales office addresses, please send an email to: [salesaddresses@nxp.com](mailto:salesaddresses@nxp.com)

antowka.ru

## 18. Contents

1	General description .....	1
2	Features and benefits .....	1
3	Applications .....	1
4	Ordering information.....	2
5	Functional diagram .....	2
6	Pinning information.....	4
6.1	Pinning .....	4
6.2	Pin description .....	4
7	Functional description .....	5
8	Limiting values.....	6
9	Recommended operating conditions.....	6
10	Static characteristics.....	7
11	Dynamic characteristics .....	9
12	Waveforms .....	12
13	Package outline .....	16
14	Abbreviations.....	20
15	Revision history.....	20
16	Legal information.....	21
16.1	Data sheet status .....	21
16.2	Definitions .....	21
16.3	Disclaimers.....	21
16.4	Trademarks.....	22
17	Contact information.....	22
18	Contents .....	23

Please be aware that important notices concerning this document and the product(s) described herein, have been included in section 'Legal information'.

© NXP Semiconductors N.V. 2016.

All rights reserved.

For more information, please visit: <http://www.nxp.com>

For sales office addresses, please send an email to: [salesaddresses@nxp.com](mailto:salesaddresses@nxp.com)

Date of release: 25 February 2016

Document identifier: 74HC\_HCT595